

QUICK START GUIDE

SETTING UP THE NEXA™ NPWT SYSTEM

1 REMOVE THE NEXA™ DEVICE FROM THE CARRY CASE

Unzip the carry case and remove the NEXA™ Device.

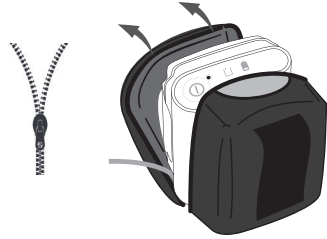

2 OPEN GREY COVER & INSERT FLUID CONTAINER PACK

Insert in the orientation shown. Push firmly until it clicks.

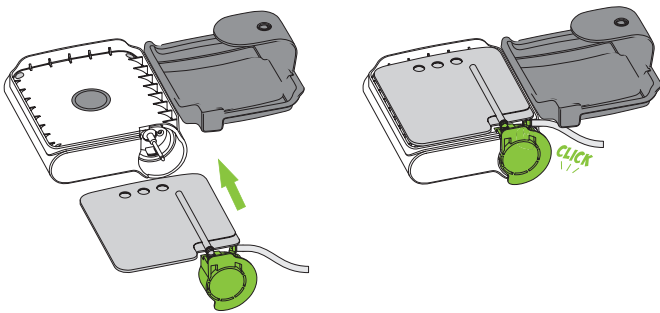

3 CLOSE GREY COVER

Close the grey cover & engage the latch to the case.

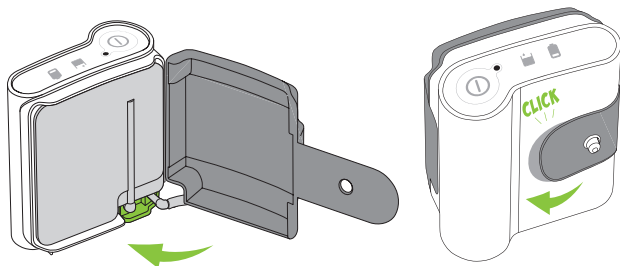

4 PLACE THE CARRY CASE UPRIGHT AND PLACE THE DEVICE INSIDE AS SHOWN BELOW. THEN ZIP IT CLOSED WITH THE TUBE EXITING AS SHOWN.

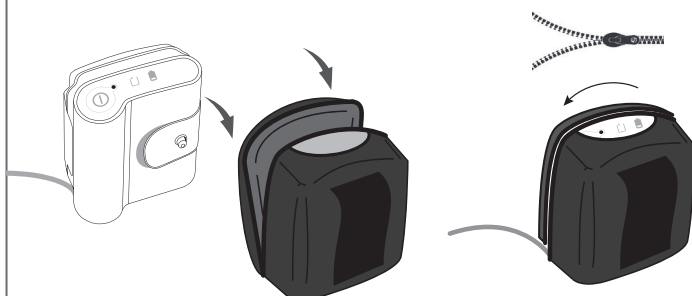

KEEP UPRIGHT USING THE STRAPS TO ATTACH TO A BED FRAME OR OTHER FURNITURE!

5 CONNECT THE DRESSING TO THE FLUID CONTAINER

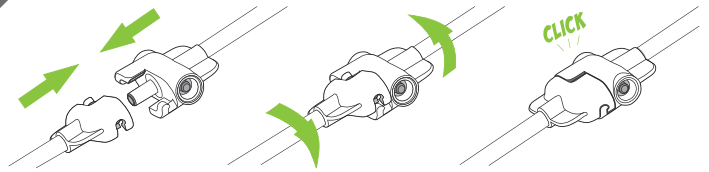

Push together

Twist

The connector will click when engaged

6 POSITION THE NEXA™ DEVICE FOR USE

- For best performance and to enable the maximum fluid containment of 120ml, use the NEXA™ Device **UPRIGHT**, even in the Carry Case.
- Use the buckles and straps to attach to a bed rail or headboard.

7 PRESS THE ON/OFF BUTTON TO START THE DEVICE

The NEXA™ Device is ON when the green light is ON.

The sounder beeps once when the unit is turned ON.



8 OPERATIONS

- The NEXA™ Device will start and run for 3 minutes at a high speed to enable pull down of the Dressing.
- After 3 minutes the Device will slow and run continuously.
- A fully charged NEXA™ Device will run for approximately 10 hrs before requiring charging.

CHARGING THE NEXA™ DEVICE

9 BATTERY LOW INDICATION

The battery is LOW when the orange light is ON. The audible sounder will beep for 5 seconds, repeating every 45 minutes.



10 CHARGING THE NEXA™ DEVICE

Insert the NEXA™ Power Supply into the socket. If the device is off, press the ON button and the charging light will flash.

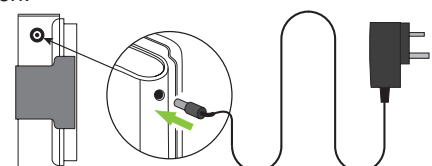

Battery is CHARGING when the orange light FLASHES.



CHANGING THE FLUID CONTAINER

11 FLUID CONTAINER FULL

The Fluid Container is FULL, or the LATCH is not engaged when the RED light is ON. The audible sounder will beep for 10 seconds, repeating every 15 minutes.

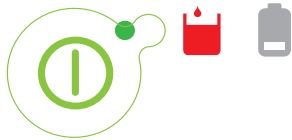

12 DISCONNECT FLUID CONTAINER FROM DRESSING

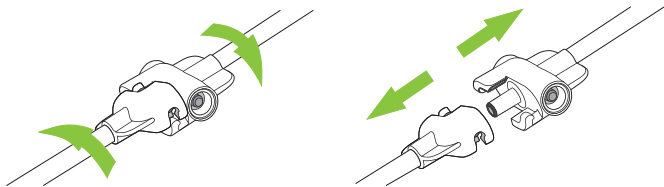

Twist to release

Pull apart

13 REMOVE THE NEXA™ DEVICE FROM CARRY CASE

The NEXA™ Device can be removed from the carry case by unzipping the case and lifting the device out.

14 OPEN GREY COVER & REMOVE FLUID CONTAINER

Pull firmly on the green pump head to remove.

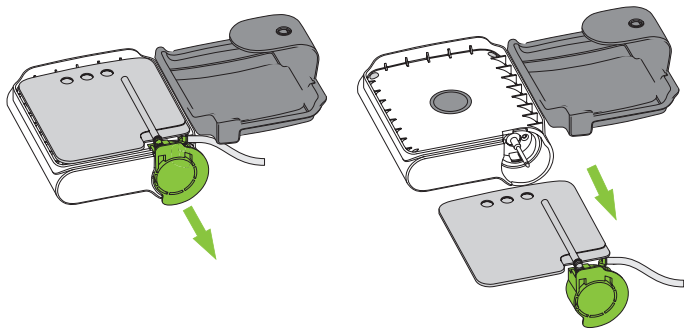

15 REPEAT STEPS 1-5 TO INSERT NEW FLUID CONTAINER

CHANGING THE DRESSING

16 CHANGING THE DRESSING

The NEXA™ Dressing is intended to be changed by a clinician or health care professional only.

Please refer to the Instructions For Use that is supplied with the Nexa™ Device for more information.

DAYS REMAINING FEATURE

17 Open the grey cover, press and hold the grey button, and at the same time press and hold the power button (for 8 seconds). Do not release the buttons until the lights start flashing.

The RED light will flash to indicate 10 days increments and the ORANGE light will flash to indicate 1-day increments.

i.e. 4 red flashes and 2 orange flashes = 42 days remaining.

TROUBLESHOOTING

DEVICE WON'T START DEVICE NOT RUNNING

- Check battery is charged or charger is plugged in correctly to the device and power source.
- Check grey latch is secured and there are no red lights.

DRESSING LEAK

- The NEXA™ Device does not have a leak alarm. The Dynamic Fluid Technology will continue to remove wound fluid irrespective of vacuum levels. This will reduce the potential for skin maceration.
- Observe the foam to determine if there is a leak and have the dressing changed at the next healthcare visit.

BLOCKAGES

A blockage will also cause the device to make an uncharacteristic slapping noise.

To resolve a blockage, check that there is no kinking in the tubing, or the tube is occluded.

If there is, either straighten the kink or replace the dressing and/or Fluid Container Pack.

CONSULT THE INSTRUCTIONS FOR USE

For a comprehensive manual and important safety information, refer to the Instructions For Use which is provided with the NEXA™ NPWT System.

For further product information, contact a NEXA™ representative.

For medical questions, contact your doctor, nurse or caregiver.

All trademarks designated herein are property of NEXA™ Medical Limited and its licensors.



CONTACT INFORMATION



AOTI Ltd.
Unit 20 Glenrock Business Park,
Ballybane, Galway, Ireland.
Website: www.aotinc.net

Email: customerservice@aotinc.net



414-10-015 Rev K